

## Panel Explanation

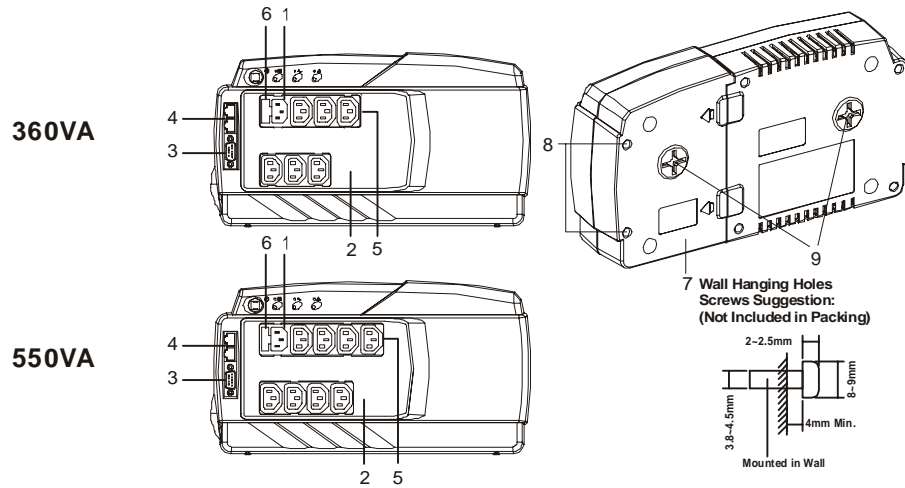

1. AC Inlet
2. Backup Outlets: 360VA -- 3pcs IEC320  
550VA -- 4pcs IEC320
3. Computer Interface: True Rs232 Communication Port
4. Modem/LAN RJ-45 JACKS
5. Surge Protection Outlets: 360VA -- 3pcs IEC320 or 2 local type sockets  
550VA -- 4pcs IEC320 or 3 local type sockets
6. AC Fuse
7. Battery Cover
8. Battery Cover Screws
9. W Holesall Hanging

## Trouble Shooting

When your UPS malfunctions during operation, you may check the list below for proper adjustment. If the adjustment still be in vain, please contact your sales agent for help.

Situation	Check Items	Solution
.Mains normal but 'Line' LED is not on.	1. Is the power switch on? 2. Is the NFB black out? 3. Is the power cord loose?	1. Press Main Switch on. 2. Restart NFB, Remove some Load. 3. Re-connect the power cord properly.
.Alarm buzzer beeps continuously when Utility is normal.	Check to see load status if it is in overload.	Remove some uncritical load.
Red LED is on	Battery voltage is too low	Recharge the UPS for hours.
.No LEDs display on the front panel		Consult with your sales agent For help.

192321642005000

# USER'S MANUAL

550VA/230V  
360VA/230V

## FCC Information

### NOTE:

This equipment has been tested and found to comply with the limits for a Class B device, pursuant to Part 15 of the FCC Rules. These limits are designed to provide reasonable protection against harmful interference in a residential installation, this equipment generates, uses and can radiate radio frequency energy and if not installed and used in accordance with the instructions may cause harmful interference to radio communications.

However, there is no guarantee that interference will not occur in a particular installation. If this equipment does cause harmful interference to radio or television reception, which can be checked by switching the equipment off and on, the user should correct the interference by one or more of the following measures.

- Move the receiving antenna to a different position.
- Move the equipment and receiver apart.
- Connect the equipment into an outlet on a different circuit.
- Consult the dealer or an experienced radio/TV technician for help.

### NOTICE:

- Any changes or modifications to the equipment not expressly approved by the party responsible for compliance could void the user's authority to operate the equipment.
- Shielded interface cables and AC power cords, if any, must be used in order to comply with the emission limits.

# IMPORTANT SAFETY INSTRUCTIONS (SAVE THESE INSTRUCTION)

This manual contains important safety instructions. Please follow all instructions carefully during installation. Read this manual thoroughly before attempting to unpack, install or operate. The maximum ambient temperature rating is 40°C for 550 and 30°C for 350 series.

**CAUTION-** To prevent the risk of fire or electric shock, install in a temperature and humidity controlled indoor area, free of conductive contaminants.

**CAUTION-** Risk of electric shock, do not remove the cover. No user serviceable parts. Refer servicing to qualified service personnel.

**CAUTION-** Risk of electric shock, hazardous live parts inside this UPS can be energized from the battery supply even when the input AC power is disconnected.

**CAUTION-** Risk of electric shock, Battery Circuit is not isolated from AC input, hazardous voltage may exist between battery terminals and ground. Test before touching.

**Notice-** The UPS is designed to be for use with Computer loads only.

## INSTALLATION OF UPS

### 1. Unpacking and Check Attached Parts.

- Unwrap the UPS
- The Standard Package includes:
  - User's Manual
  - A/C Input Power Cord (Not available for hand wiring condition models)
  - IEC output cables ( for the UPS with IEC sockets only)
  - RJ11 Phone Jack Cable
  - UPS communication kit (optional)

### 2. Line Connection

First, connect the UPS with the AC Mains to recharge internal battery for over 12 hours. (Please proceed charge process upon receipt. After more than 12 hours in charging, connect the line of your computer with the sockets of the UPS.)

### 3. Operation Test

Connect the UPS to the wall receptacle.

Please follow the general testing procedures to check if your UPS meets working requirements.

- Push on the Main Switch to check the Green Line(⤵) Led is on .
- Connect your computer equipment with sockets of the UPS and pull off the Power Cable of the UPS from the wall receptacle to check if Alarm buzzer is beeping.
- Try the field working condition by running some application programs on your computer and repeating step.
- Check if the UPS is initiated properly to support continuous operation.

**Important Notice: Please plug the UPS into the wall outlet to charge the UPS for over 8 hours before using the UPS.**

## INTRODUCING THE FRONT PANEL AND REAR PANEL AND ADDITIONAL PARTS

### Front Panel Explanation

#### 1. Check Battery (☹):

Red LED lights up when Battery Low or fault.

#### 2. Line (⤵):

Green LED remains at a standstill when Utility Normal. (When Utility fails, alarm buzzer beeps continuously)

#### 3. Surge protected LED (⚡):

Green LED remains at a standstill when surge protection function is normal.

#### 4. Main Switch (⏻):

- To Control on /off the UPS when Utility is normal.
- To enable "DC-Star" Function when Utility fails. (To enable DC Start properly, you are recommended to connect <80% output load with the UPS only)

P.S Make sure the computer connected to the UPS is switched on before enable the "DC-Star" function. You are not recommended to add some other computer or peripherals after "DC-Start" function is activated.

